

**Method to check the estimated  $\delta$ -V curve  
of the hinged side vane safety system and checking  
of the  $\delta$ -V curve of the VIRYA-3.3D windmill (7.14 % cambered steel blades)**

ing. A. Kragten

February 2005

KD 223

It is allowed to copy this report for private use.

Engineering office Kragten Design  
Populierenlaan 51  
5492 SG Sint-Oedenrode  
The Netherlands  
telephone: +31 413 475770  
e-mail: [info@kdwindturbines.nl](mailto:info@kdwindturbines.nl)  
website: [www.kdwindturbines.nl](http://www.kdwindturbines.nl)

Contains	page
1 Introduction	3
2 Description of the hinged side vane safety system	4
3 Determination of the moment equations	6
3.1 Determination of $M_{\text{rotor}}$	6
3.2 Determination of $M_{\text{vt}}$	11
3.3 Determination of $M_{\text{vh}}$	17
3.4 Determination of $M_{\text{G}}$	18
3.5 Determination of the moment equations	18
4 Checking of the $\delta$ -V curve of the VIRYA-3.3D	21
5 References	28

## 1 Introduction

Windmills with fixed rotors can be protected against too high forces and too high rotational speeds by turning the rotor out of the wind. This can be done around a vertical and around an horizontal axis. All present VIRYA windmills developed by Kragten Design turn out of the wind around a vertical axis and make use of the so called hinged side vane safety system. Safety systems for which the rotor turns out of the wind around a vertical axis are described in report R 999 D (ref. 1). The hinged side vane system is described in chapter 7.6 of report R 999 D. Because report R 999 D is no longer available, theories, figures and formulas from R 999 D will be incorporated in this report KD 223, to guarantee that the knowledge of this safety system is kept available. The theory is also incorporated in report KD 213 for the VIRYA-4.2 windmill (ref. 2) but as the VIRYA-4.2 has a Gö 623 airfoil, the formula for the self orientating moment is different.

Although the hinged side vane system is described for the first time in report R 515 D (ref. 3) of the former Wind Energy Group of the University of Technology Eindhoven, it is developed by me privately. It is used for the first time in my Drieka-4 windmill in 1982. Later it is also use in the water pumping windmill CWD 2000 in 1986. From 1986 it is used in all VIRYA windmills developed by Kragten Design. At this moment it is also used in water pumping windmills driving a rope pump in Nicaragua.

In chapter 2 of R 999 D the reasons are given why a safety system is necessary. These reasons are:

- 1 Limitation of the axial force or thrust on the rotor to limit the load on the rotor blades, the tower and the foundation.
- 2 Limitation of the rotational speed of the rotor to limit the centrifugal force in the blades, imbalance forces, high gyroscopic moments in the blades and the rotor shaft, to prevent flutter for blades with low torsion stiffness and to prevent to high rotational speeds of the load which is relevant for mechanical coupling to a piston pump.
- 3 Limitation of the yawing speed to limit high gyroscopic moments in the blades and the rotor shaft.

In chapter 5 of R 999 D the ideal safety system is described. Hereby it is assumed that the windmill rotor is perpendicular to the wind direction up to the rated wind speed  $V_{\text{rated}}$  and that the rotor is turned out of the wind for wind speeds higher than  $V_{\text{rated}}$  such that the component of the wind speed perpendicular to the rotor plane is kept constant. This appears to be the case if the yaw angle  $\delta$  meets the formula:

$$\delta = \arccos V_{\text{rated}} / V \quad (^\circ) \quad (1)$$

In this case the rotational speed, the thrust, the torque and the power will be kept constant too. Such an ideal system can only be realised if the moment which turns the head out of the wind is supplied only by the thrust and if the balancing moment of the vane is kept constant. In practice this is not possible because the side force on the rotor and the so called self orientating moment also contribute to the rotor moment and because it is difficult to realise a constant vane moment. The real characteristic of the safety system, given by the  $\delta$ -V curve, will therefore deviate from the ideal curve. I think that the deviation for the hinged side vane system is the minimum of all known safety systems for which the rotor turns out of the wind.

The  $\delta$ -V curve for the older VIRYA windmills were estimated on the basis of practical experience but now a method will be given with which an estimated curve can be checked.

## 2 Description of the hinged side vane safety system

In the first description of the safety system (see R 515 D) a head geometry was used which was later changed on several points. The geometry which will be described now is used in all present VIRYA windmills although the geometry is not exactly congruent for all types.

The rotor axis has a relatively large eccentricity  $e$  to the right side of the tower axis. The vane arm is making an angle  $\phi_1 = 45^\circ$  with the rotor axis and therefore the vane blade juts out left from the rotor plane. The vane blade is hanging on two or three hinges which are connected to a strip which makes an angle of  $15^\circ$  backwards with the vane arm. The hinge axis therefore makes an angle  $\phi_2 = 30^\circ$  with the rotor axis. If there is no wind, the vane blade is hanging vertical because of its weight. The geometry of rotor and head are chosen such that the rotor moment  $M_{\text{rotor}}$  and the vane moment around the tower axis  $M_{\text{vt}}$  are in balance for very low wind speeds if the rotor is perpendicular to the wind.

The vane moment is caused by the aerodynamic force working on the vane blade and by the aerodynamic force working on the vane arm. At low wind speeds the aerodynamic force on the vane arm can be neglected. If the rotor is perpendicular to the wind, the side force on the rotor and the self orientating moment are both zero and so the balance of moments around the tower axis is only determined by the rotor thrust and the aerodynamic force on the vane blade.

The balance of moments around the vane hinge axis is determined by the aerodynamic normal force  $N$  working on the vane blade and by the vane weight  $G$ . For low wind speeds,  $N$  is only little and therefore the vane blade will make a little angle  $\theta$  with the vertical position. The horizontal component of  $N$ ,  $N \cos\theta$ , has then almost the same value as  $N$  which means that the rotor moment and the vane moment will increase by the same factor if the wind speed increases. This means that the rotor stays perpendicular to the wind if this true at very low wind speeds. However, at angles  $\theta$  larger than about  $25^\circ$ ,  $N \cos\theta$  becomes substantially lower than  $N$  and therefore the rotor moment will increase more than the vane moment. Above the wind speed where this happens, the rotor will turn out of the wind gradually. The wind speed where the rotor starts to turn out of the wind is determined by the ratio in between the vane blade weight and the vane blade area. At very high wind speeds the vane blade position is almost horizontally and the horizontal component of  $N$  is much lower than  $N$ . Then the rotor turns out of the wind by about  $70^\circ$ .

The vane blade has no stop for the vertical position but it has a stop for the almost horizontal position. This stop prevents that the normal force can become negative during heavy wind gusts. If the normal force can not become negative, flutter of the vane blade is prevented which otherwise could happen at high wind speeds if the vane arm is too flexible.

The system can only be described well at low and at high wind speeds but it appears to function well also at moderate wind speeds if the vane blade is square or almost square and if the eccentricity  $e$  is not taken too low. The hinged side vane safety system is given for low wind speeds in figure 1 and for high wind speeds in figure 2.

Because the vane blade juts out left from the rotor it is in the undisturbed wind speed. Therefore, to realise a certain force, a much lower area is required than for a vane blade placed in the rotor wake. Because the vane arm is integrated with the head, the moment of inertia of the head around the tower axis is very large. The light vane blade will move fast during wind gusts but the head will follow only slowly. This limits the gyroscopic moments in the blades and in the rotor shaft. At high wind speeds only a little change of the yaw angle  $\delta$  is required to come to a new balance of moments. Therefore the system is very stable at high wind speeds.

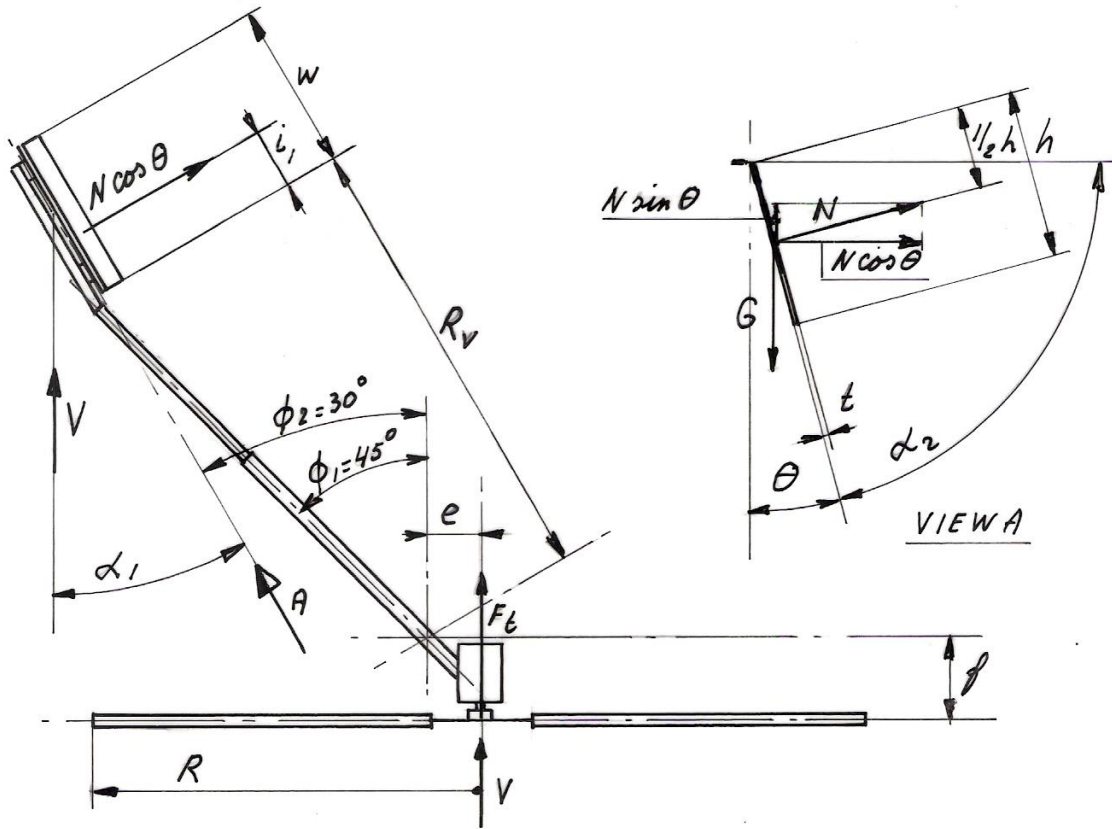

figure 1 The hinged side vane safety system for low wind speeds

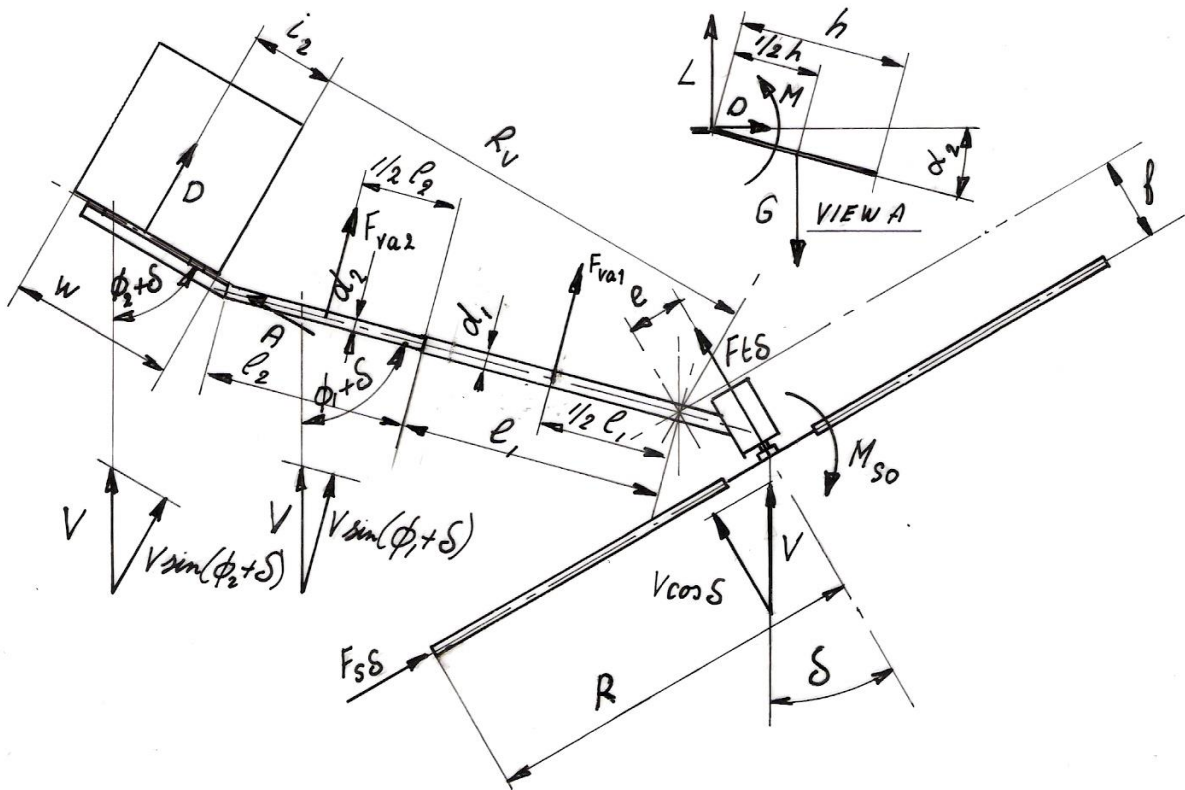

figure 2 The hinged side vane safety system for high wind speeds

### 3 Determination of the moment equations

For the moment equations a quasi-static situation is assumed. This means that dynamic effects which are the result of the moments to accelerate the vane blade and the head are neglected. The moment of friction of the vane blade hinges and of the head bearings is also neglected. The aerodynamic effect of the strip to which the vane blade is connected is also neglected.

The angle to the left from the rotor axis with respect to the wind direction is called  $\delta$ . Because of the eccentricity  $e$ , a thrust moment  $M_{F_t\delta}$  is exerted by the thrust  $F_{t\delta}$  around the tower axis. The rotor wants to turn out of the wind left hand because of  $M_{F_t\delta}$ . Because of the distance  $f$  in between the rotor plane and the tower axis, a side force moment  $M_{F_s\delta}$  is exerted by the side force  $F_{s\delta}$ . The rotor wants to turn out of the wind left hand because of  $M_{F_s\delta}$ . Because of the so called self orientating moment  $M_{so}$  the rotor wants to turn in the wind and for a positive value of  $\delta$ , the rotor wants to turn in the wind right hand.  $M_{F_s\delta}$  and  $M_{so}$  are only there for a certain value of  $\delta$ . The resulting moment of  $M_{F_t\delta}$ ,  $M_{F_s\delta}$  and  $M_{so}$  is called the rotor moment  $M_{rotor}$ .

The normal force  $N$  on the vane blade, exerts for low wind speeds on a distance  $i_1$  from the front side of the vane blade. For high wind speeds, the distance  $i_2$  is used but then it is not the normal force  $N$  which is used but the drag force  $D$ . On the two segments of the vane arm the drag forces  $F_{va1}$  and  $F_{va2}$  are working. These forces are neglected for low wind speeds. The vane moment around the tower axis exerted by  $N \cos\delta$  or by  $D$ ,  $F_{va1}$  and  $F_{va2}$  is called  $M_{vt}$ . Because of  $M_{vt}$ , the rotor wants to turn in the wind right hand. The vane moment around the vane hinge axis exerted by  $N$  or by the aerodynamic moment  $M$  is called  $M_{vh}$ . The moment around the vane hinge axis exerted by the weight of the vane blade  $G$  is called  $M_G$ .

$M_{rotor}$ ,  $M_{vt}$ ,  $M_{vh}$  and  $M_G$  are first determined separately. Next balance of moments is given around the vane hinge axis and around the tower axis for low and for high wind speeds.

#### 3.1 Determination of $M_{rotor}$

The formulas for a yawing rotor are given in chapter 7 of report KD 35 (ref. 4). It is assumed that only the component of the wind speed perpendicular to the rotor plane,  $V \cos\delta$ , is determined for the rotational speed, the thrust, the torque and the power. The thrust for a yawing rotor is given by formula 7.4 of KD 35 which is copied as formula 2.

$$F_{t\delta} = C_t * \cos^2\delta * \frac{1}{2}\rho V^2 * \pi R^2 \quad (\text{N}) \quad (2)$$

$F_{t\delta}$  exerts a moment  $M_{F_t\delta}$  around the tower axis for which it is valid that:

$$M_{F_t\delta} = F_{t\delta} * e \quad (\text{Nm}) \quad (3)$$

$M_{F_t\delta}$  is working to the left and this direction is taken positive for  $M_{F_t\delta}$ .

(2) + (3) gives:

$$M_{F_t\delta} = C_t * e * \cos^2\delta * \frac{1}{2}\rho V^2 * \pi R^2 \quad (\text{Nm}) \quad (4)$$

For the side force on the rotor  $F_{s\delta}$ , no formula is given in KD 35. If one would calculate with the component of the wind speed in the rotor plane  $V \sin\delta$ , the side force would be proportional to  $\sin^2\delta$ . However, from measurements (see figure 23, report R 999 D) it is found that  $F_{s\delta}$  increases much faster than a  $\sin^2\delta$  function for small values of  $\delta$ . A  $\sin\delta$  function gives a better approximation.

For very large angles  $\delta$ , the tip speed of the rotor is only little with respect to the wind speed. The side area of the rotor  $A_s$ , then can be seen as a drag area with a drag coefficient  $C_d$ . The ratio  $i$  in between  $A_s$  and the swept rotor area  $\pi * R^2$  depends on the type of rotor. For fast running rotors as used in the VIRYA windmills,  $A_s$  is very small with respect to the swept rotor area because the chord, the airfoil thickness and the blade angles are small. In this report the three bladed VIRYA-3.3D rotor is taken which has a design tip speed ratio of 5. For this rotor it is determined that  $i = A_s / (\pi * R^2) = 0.014$ . The drag coefficient  $C_d$  depends on the airfoil and is rather low if an aerodynamic airfoil is used. The yaw angle  $\delta$  is large at very high wind speeds and the lower blade sees a much larger relative wind speed than the upper blade. It is assumed that the average  $C_d$  value for the whole rotor is 1. The side force  $F_{s\delta}$  for a yawing rotor is now given by:

$$F_{s\delta} = C_d * \sin\delta * \frac{1}{2}\rho V^2 * i * \pi R^2 \quad (\text{N}) \quad (5)$$

$F_{s\delta}$  exerts a moment  $M_{F_{s\delta}}$  around the tower axis which is given by:

$$M_{F_{s\delta}} = F_{s\delta} * f \quad (\text{Nm}) \quad (6)$$

$M_{F_{s\delta}}$  is working to the left and this direction is taken positive for  $M_{F_{s\delta}}$ .

(5) + (6) gives:

$$M_{F_{s\delta}} = C_d * f * i * \sin\delta * \frac{1}{2}\rho V^2 * \pi R^2 \quad (\text{Nm}) \quad (7)$$

In KD 35 no formula is given for the self orientating moment  $M_{so}$ .  $M_{so}$  is created because the exertion point of the thrust doesn't coincide with the hart of the rotor. There is only little known about  $M_{so}$  and only some very rough measurements have been performed which are given in report R 344 D (ref. 5). For these measurement an unloaded two bladed rotor was used with a design tip speed ratio of 5 and provided with a curved sheet airfoil. Because the thrust coefficient for  $\lambda_{unl}$  has almost the same value as for  $\lambda_d$ , and because the VIRYA-3.3D has also design tip speed ratio of 5, it is assumed that the measured values can be used for the VIRYA-3.3D.

$M_{so}$  is given by:

$$M_{so} = C_{so} * \frac{1}{2}\rho V^2 * \pi R^3 \quad (\text{Nm}) \quad (8)$$

$C_{so}$  depends on the yaw angle  $\delta$  and appears to have a maximum for  $\delta = 30^\circ$ . The measured  $C_{so}-\delta$  curve can be approximated by two goniometrical functions, one function for  $0^\circ < \delta < 40^\circ$  and one function for  $40^\circ < \delta < 90^\circ$ . These functions are:

$$C_{so} = 0.045 \sin 3\delta \quad (-) \quad (\text{for } 0^\circ < \delta < 40^\circ) \quad (9)$$

$$C_{so} = 0.0664 \cos^2\delta \quad (-) \quad (\text{for } 40^\circ < \delta < 90^\circ) \quad (10)$$

If the direction of the moment for a negative value of  $\delta$  is taken the same as for a positive value of  $\delta$ , formula 9 can also be used for  $-40^\circ < \delta < 0^\circ$ . The path of both curves is given in figure 3.

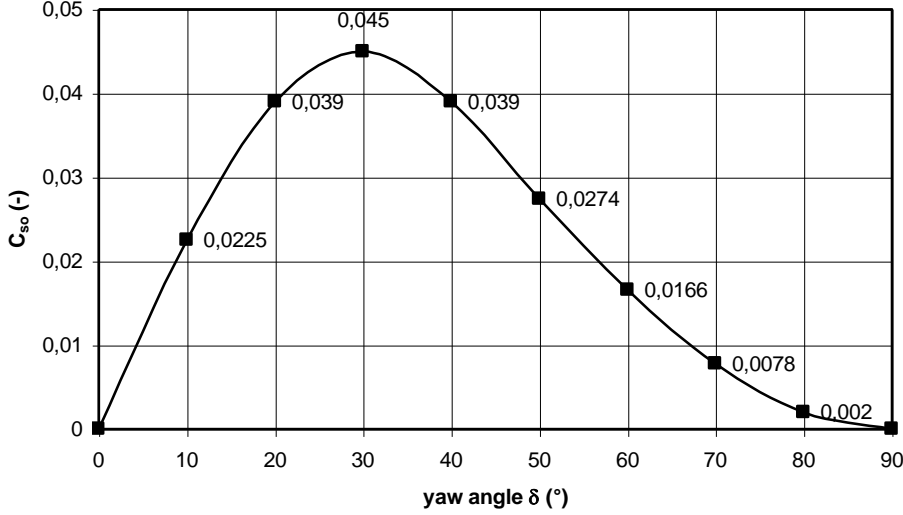

figure 3 Path of  $C_{so}$  as a function of the yaw angle  $\delta$

(8) + (9) gives:

$$M_{so} = 0.045 \sin 3\delta * \frac{1}{2}\rho V^2 * \pi R^3 \quad (\text{Nm}) \quad (\text{for } 0^\circ < \delta < 40^\circ) \quad (11)$$

(8) + (10) gives:

$$M_{so} = 0.0664 \cos^2\delta * \frac{1}{2}\rho V^2 * \pi R^3 \quad (\text{Nm}) \quad (\text{for } 40^\circ < \delta < 90^\circ) \quad (12)$$

$M_{so}$  is working to the right for a positive angle  $\delta$  and this direction is taken positive for  $M_{so}$ . For the total rotor moment  $M_{rotor}$  which is exerted to the right by  $M_{Ft\delta}$ ,  $M_{Fs\delta}$  en  $M_{so}$  it is valid for the assumed directions of the moments that:

$$M_{rotor} = M_{Ft\delta} + M_{Fs\delta} - M_{so} \quad (\text{Nm}) \quad (13)$$

(4) + (7) + (11) + (13) gives:

$$M_{rotor} = C_t * e * \cos^2\delta * \frac{1}{2}\rho V^2 * \pi R^2 + C_d * f * i * \sin\delta * \frac{1}{2}\rho V^2 * \pi R^2 - 0.045 \sin 3\delta * \frac{1}{2}\rho V^2 * \pi R^3 \quad \text{or}$$

$$M_{rotor} = \frac{1}{2}\rho V^2 * \pi R^2 (C_t * e * \cos^2\delta + C_d * f * i * \sin\delta - 0.045 * R \sin 3\delta) \quad (\text{Nm}) \quad (\text{for } 0^\circ < \delta < 40^\circ) \quad (14)$$

(4) + (7) + (12) + (13) gives:

$$M_{rotor} = C_t * e * \cos^2\delta * \frac{1}{2}\rho V^2 * \pi R^2 + C_d * f * i * \sin\delta * \frac{1}{2}\rho V^2 * \pi R^2 - 0.0664 \cos^2\delta * \frac{1}{2}\rho V^2 * \pi R^3 \quad \text{or}$$

$$M_{rotor} = \frac{1}{2}\rho V^2 * \pi R^2 (C_t * e * \cos^2\delta + C_d * f * i * \sin\delta - 0.0664 * R \cos^2\delta) \quad (\text{Nm}) \quad (\text{for } 40^\circ < \delta < 90^\circ) \quad (15)$$



To get an impression of the contribution of  $M_{Ft\delta}$ ,  $M_{Fs\delta}$  and  $M_{so}$  to  $M_{rotor}$ , the moments are made dimensionless by dividing by  $\frac{1}{2}\rho V^2 * \pi R^3$ . The formulas 4, 7, 11, 12 and 13 change into 16, 17, 18, 19 and 20 for  $C_{MFt\delta}$ ,  $C_{MFS\delta}$ ,  $C_{Mso}$  and  $C_{Mrotor}$ .

$$C_{MFt\delta} = C_t * (e / R) * \cos^2\delta \quad (-) \quad (16)$$

$$C_{MFS\delta} = C_d * (f / R) * i * \sin\delta \quad (-) \quad (17)$$

$$C_{Mso} = 0.045 \sin 3\delta \quad (-) \quad (\text{for } 0^\circ < \delta < 40^\circ) \quad (18)$$

$$C_{Mso} = 0.0664 \cos^2\delta \quad (-) \quad (\text{for } 40^\circ < \delta < 90^\circ) \quad (19)$$

$$C_{Mrotor} = C_{MFt\delta} + C_{MFS\delta} - C_{Mso} \quad (-) \quad (20)$$

Now the path of  $C_{MFt\delta}$ ,  $C_{MFS\delta}$ ,  $C_{Mso}$  and  $C_{Mrotor}$  is determined as a function of  $\delta$  for the VIRYA-3.3D rotor. For this rotor it is valid that:  $R = 1.65$  m,  $e = 0.33$  m and  $f = 0.42$  m. It was assumed earlier that  $i = 0.014$ . The theoretical thrust coefficient  $8/9 = 0.89$  for  $\lambda = \lambda_d$ . However in practice it is a lot lower because the inner part of the rotor is not effective and because a part of the thrust is lost by tip and root losses. Assume  $C_t = 0.75$ . For the drag coefficient it was earlier assumed that  $C_d = 1$ . Substitution of these values in formula 16 and 17 gives:

$$C_{MFt\delta} = 0.15 \cos^2\delta \quad (-) \quad (21)$$

$$C_{MFS\delta} = 0.00356 \sin\delta \quad (-) \quad (22)$$

The moment coefficients are calculated for values of  $\delta$  in between  $\delta = -40^\circ$  and  $\delta = 90^\circ$  rising with  $10^\circ$ . The results of the calculations are given in table 1 and figure 4. If the direction of moments for negative values of  $\delta$  is taken the same as for positive values of  $\delta$ , formulas 18, 21 and 22 can also be used for negative values of  $\delta$ .

$\delta$ ( $^\circ$ )	$C_{MFt\delta}$ (-)	$C_{MFS\delta}$ (-)	$C_{Mso}$ (-)	$C_{Mrotor}$ (-)
-40	0.08802	-0.00229	-0.03897	0.12470
-30	0.11250	-0.00178	-0.04500	0.15572
-20	0.13245	-0.00122	-0.03897	0.17020
-10	0.14548	-0.00062	-0.02250	0.16736
0	0.15000	0	0	0.15000
10	0.14548	0.00062	0.02250	0.12360
20	0.13245	0.00122	0.03897	0.09470
30	0.11250	0.00178	0.04500	0.06928
40	0.08802	0.00229	0.03897	0.05134
50	0.06198	0.00273	0.02743	0.03728
60	0.03750	0.00308	0.01660	0.02398
70	0.01755	0.00335	0.00777	0.01313
80	0.00452	0.00351	0.00200	0.00603
90	0	0.00356	0	0.00356

table 1 Calculated values for  $C_{MFt\delta}$ ,  $C_{MFS\delta}$ ,  $C_{Mso}$  and  $C_{Mrotor}$  for the VIRYA-3.3D rotor

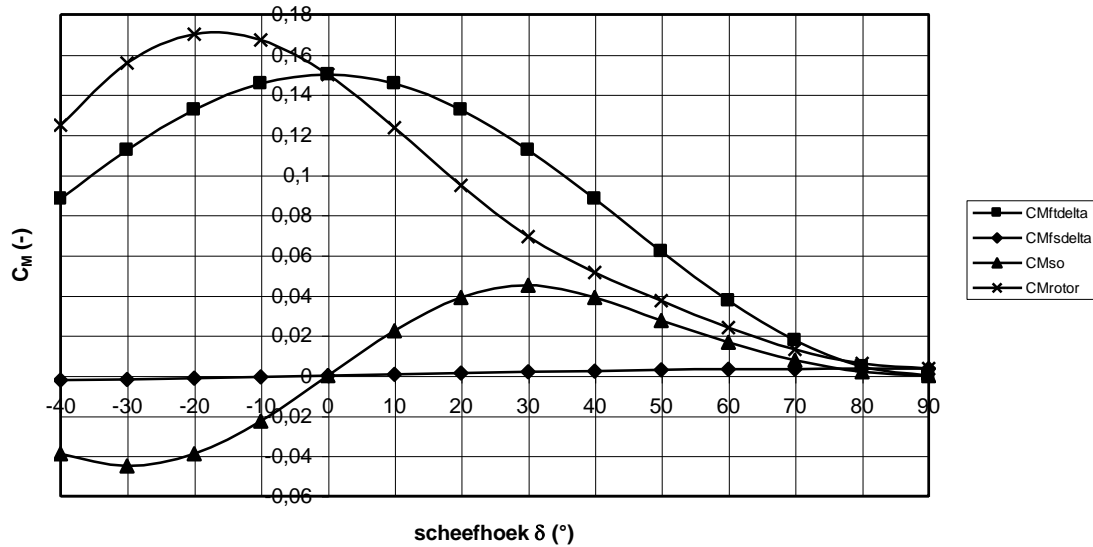

figure 4 Path of  $C_{MFt\delta}$ ,  $C_{MFs\delta}$ ,  $C_{Ms0}$  and  $C_{Mrotor}$  for the VIRYA-3.3D rotor

In figure 4 it can be seen that the contribution of  $C_{MFs\delta}$  to  $C_{Mrotor}$  can be neglected except for very large angles  $\delta$ . The contribution of  $C_{Ms0}$  to  $C_{Mrotor}$  can not be neglected and causes that the decrease of the  $C_{Mrotor}-\delta$  curve at increasing  $\delta$  is much faster than for the  $C_{MFt\delta}-\delta$  curve. For angles  $\delta$  in between  $25^\circ$  and  $60^\circ$ ,  $C_{Mrotor}$  is about a factor 0.65 van  $C_{MFt\delta}$ .  $C_{Mrotor}$  has a maximum at about  $\delta = -17^\circ$ .

The path found in figure 4 for the dimensionless moment coefficients is also valid for the real moments for a certain wind speed. Formula 1 is the formula for the ideal  $\delta$ -V curve for which  $V \cos\delta$  is constant above  $V_{rated}$ . If  $V \cos\delta$  is kept constant above  $V_{rated}$ , it means that  $n_\delta$ ,  $M_{Ft\delta}$  and  $P_\delta$  will be constant too. If  $M_{rotor}$  would be determined only by  $M_{Ft\delta}$  an ideal  $\delta$ -V curve could be realised if  $M_{vt}$  is kept constant. However, the decrease of  $M_{rotor}$  is more than the decrease of  $M_{Ft\delta}$  which means that  $M_{vt}$  should decrease above  $V_{rated}$  to prevent increase of the rotational speed. This can not be realised easy and therefore the real  $V_{rated}$  is higher than the theoretical value  $V_{rated th}$  which belongs to the point where the ideal  $\delta$ -V curve intersects with the x-axis.

The VIRYA-3.3D has a vane blade made of 9 mm water proof meranty plywood. The estimated  $\delta$ -V curve for this vane blade is given in figure 5. The estimation is based on practical experience with the VIRYA-1.8D windmill. For the rated wind speed it is assumed that  $V_{rated} = 11$  m/s and for this wind speed the yaw angle  $\delta = 35^\circ$ . The rotor starts to turn out of the wind above a wind speed of 5 m/s. It is assumed that the ideal  $\delta$ -V curve is followed for wind speeds higher than 11 m/s. It can be calculated that the ideal  $\delta$ -V curve intersects with the x-axis at  $V_{rated th} = 11 * \cos 35^\circ = 9.0107$  m/s. In chapter 4 it will be checked if this estimated  $\delta$ -V curve is right or acceptable.

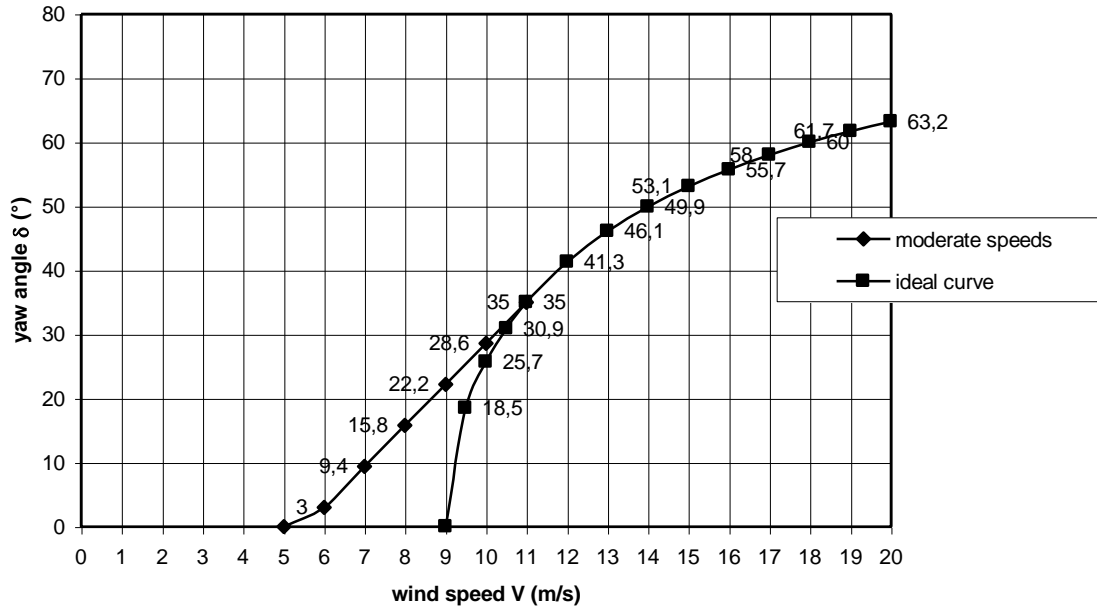

figure 5 Estimated  $\delta$ -V curve of the VIRYA-3.3D windmill

### 3.2 Determination of $M_{vt}$

The vane moment around the tower axis  $M_{vt}$  is determined by the forces acting on the vane blade and on the vane arm. For the VIRYA-3.3D, the vane arm consists of one section of 2½" gas pipe and one section of 1½" gas pipe. At low wind speeds the rotor is about perpendicular to the wind and the largest part of the vane arm is in the rotor wake. There, the wind speed is substantial lower than the undisturbed wind speed. The vane arm makes an angle of about 45° with the wind direction and the component of the wind speed perpendicular to the vane arm is even more lower than the undisturbed wind speed. As long as the vane blade is roughly vertical, the contribution of the forces on the vane arm can be neglected compared to the force on the vane blade. For the balance of moments around the tower axis only the horizontal component  $N \cos\theta$  of the normal force  $N$  has to be taken into account. For low wind speeds  $M_{vt}$  is therefore given by ( see figure 1):

$$M_{vt} = N \cos\theta * (R_v + i_1) \quad (\text{Nm}) \quad (\text{for low wind speeds}) \quad (23)$$

For high wind speeds the rotor turns out of the wind and therefore a large part of the vane arm comes outside the rotor wake. At a large angle  $\theta$ ,  $N \cos\theta$  becomes much smaller than  $N$  and now the forces  $F_{va1}$  and  $F_{va2}$ , acting on the two segments of the vane arm, can no longer be neglected with respect to the force on the vane blade. For large values of  $\theta$  it appears to be smart not to use  $N \cos\theta$  for the calculations but to use the drag force  $D$ . For high wind speeds  $M_{vt}$  is therefore given by (see figure 2):

$$M_{vt} = D * (R_v + i_2) + F_{va1} * \frac{1}{2} l_1 + F_{va2} * (l_1 + \frac{1}{2} l_2) \quad (\text{Nm}) \quad (\text{for high wind speeds}) \quad (24)$$

For this situation  $D$  exerts in the middle of the vane blade at  $i_2 = \frac{1}{2} w$ . For the vane blade, a square plate is used. The aerodynamic characteristics for a square plate have been determined by Flachsbart and are given at page 3-4 of the TUE report R 443 D (ref. 6). The advantage of a square, or a hardly square plate is that the aerodynamic characteristics are independent of which side is taken as chord. For a rectangular plate the characteristics differ depending on which side is taken as chord. The characteristics are almost independent of the Reynolds number.

For the square plate, used as vane blade for the VIRYA windmills, the sheet width  $w$  is functioning as chord at low wind speeds and the sheet height  $h$  is functioning as chord at high wind speeds. Aerodynamic airfoils are normally measured with respect to the quart chord point. However, the square plate has been measured with respect to the leading edge of the sheet. This is favourable because this edge coincides with the front edge for low wind speeds and with the hinge axis for high wind speeds. For high wind speeds it is therefore not necessary to transpose the measured moment coefficient to another axis, so lift and drag can exert on the hinge axis without giving a moment. For low wind speeds however, it is easier to use the normal force  $N$  for calculations but then the distance  $i_1$ , which depends on the angle  $\alpha_1$ , has to be determined.

The normal coefficient is not given by Flachsbart but can be determined from the measured  $C_l$  and  $C_d$  coefficients. If it is assumed that there is no force acting in the direction of the plate, which is true except for very low values of  $\alpha$ , the relation is very simple and is given by:

$$C_n = \sqrt{(C_l^2 + C_d^2)} \quad (-) \quad (25)$$

If it is assumed that there might be a force working in the plate direction the relation is:

$$C_n = C_l \cos\alpha + C_d \sin\alpha \quad (-) \quad (26)$$

For angles  $\alpha$  larger than  $5^\circ$  both formulas appear to give the same result, but because formula 26 is also correct for small values of  $\alpha$ , this one is favoured.

The values measured by Flachsbart of  $C_l$ ,  $C_d$  and  $C_m$  as a function of  $\alpha$  are copied in table 2. The calculated values of  $C_n$  using formula 26 are also given in table 2.

$\alpha$ ( $^\circ$ )	$C_l$ (-)	$C_d$ (-)	$C_m$ (-)	$C_n$ (-)	$i_1 / w = C_m / C_n$
0	0	0.0232	0	0	-
5.0	0.161	0.0363	0.035	0.164	0.214
9.9	0.361	0.0842	0.098	0.370	0.265
14.9	0.591	0.176	0.193	0.616	0.313
19.9	0.831	0.313	0.299	0.888	0.337
24.6	1.015	0.479	0.402	1.122	0.358
34.7	1.300	0.904	0.606	1.583	0.383
37.7	1.330	1.026	0.668	1.680	0.398
39.7	1.327	1.100	0.708	1.724	0.411
40.7	1.323	1.101	0.724	1.721	0.421
37.9	0.887	0.703	0.478	1.132	0.422
39.9	0.840	0.709	0.463	1.099	0.421
40.9	0.832	0.722	0.467	1.102	0.424
41.9	0.821	0.737	0.480	1.103	0.435
46.9	0.751	0.799	0.472	1.097	0.430
54.9	0.655	0.925	0.493	1.133	0.435
64.4	0.484	1.020	0.505	1.129	0.447
75.0	0.302	1.085	0.528	1.126	0.469
90.0	0	1.150	0.566	1.150	0.492

table 2 Aerodynamic coefficients of a square plate for Reynolds values  $2 * 10^5$ ,  $4 * 10^5$ ,  $6 * 10^5$  and  $8 * 10^5$

For an angle  $\alpha$  of about  $40^\circ$  there is instability because the airfoil stalls. What is measured depends on the measuring direction, if  $\alpha$  is increased or decreased. Therefore we find a discontinuity in the curve. The calculated values of  $C_n$  as a function of  $\alpha$  are given in figure 6.

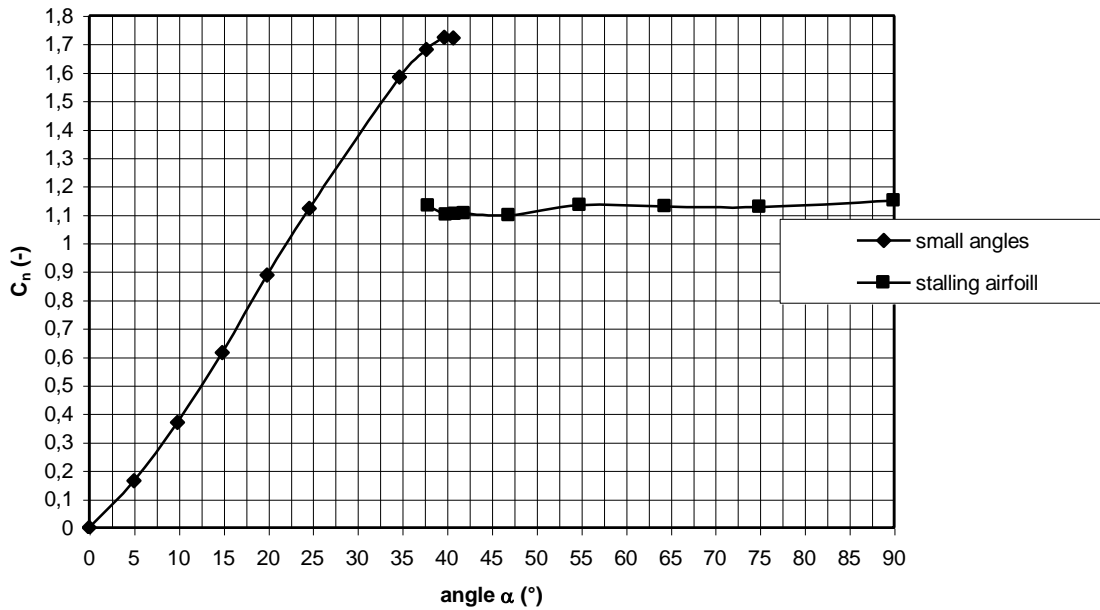

figure 6 Calculated  $C_n$ - $\alpha$  curve for a square sheet

For  $0^\circ < \alpha < 40^\circ$ , the  $C_n$ - $\alpha$  curve is almost a straight line through the origin. For  $40^\circ < \alpha < 90^\circ$ ,  $C_n$  has an almost constant value of about 1.13.

The exertion point of the normal force  $N$  lays at a distance  $i_1$  from the leading edge. The value of  $i_1$  depends on the angle  $\alpha$  and on the chord which is  $w$  for low wind speeds. The value of  $i_1$  is found by taking balance of moments around the leading edge. As the lift  $L$  and the drag  $D$  are exerting on the leading edge, they are giving no moment. Therefore the balance of moments is only determined by the aerodynamic moment  $M$  and by the normal force  $N$ . Because of this effect it can be derived that:

$$i_1 / w = C_m / C_n \quad (-) \quad (27)$$

(26) + (27) gives:

$$i_1 / w = C_m / (C_l \cos\alpha + C_d \sin\alpha) \quad (28)$$

Using formula 28, the values for  $i_1 / w$  have been calculated and are also given in table 2. The path of  $i_1 / w$  as a function of  $\alpha$  is given in figure 7. So lift  $L$ , drag  $D$  and moment  $M$  are replaced by the normal force  $N$  exerting on a distance  $i_1$  from the leading edge.

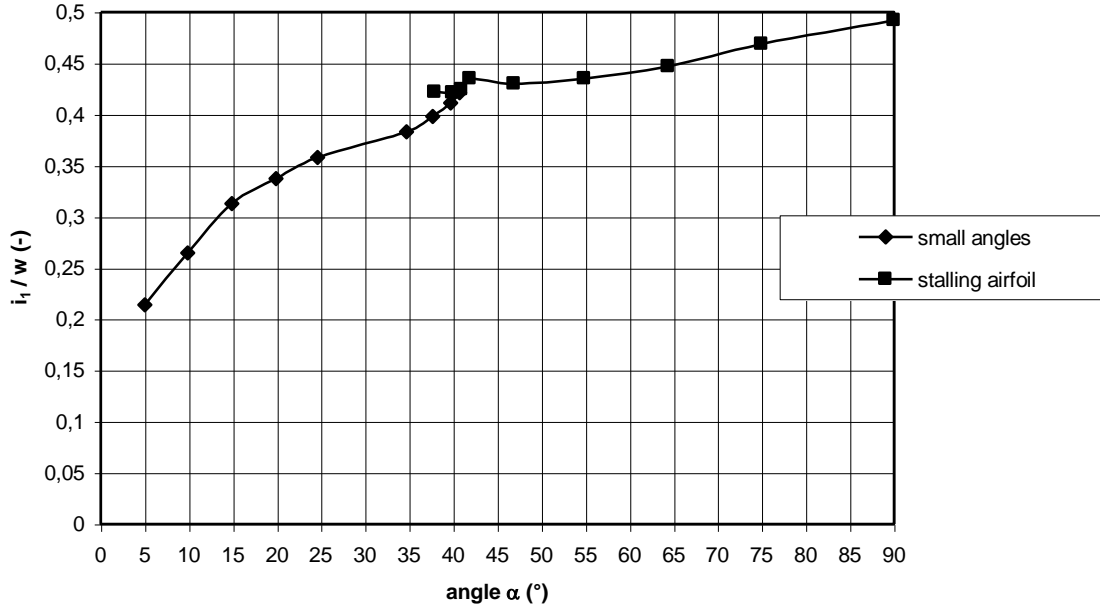

figure 7 Path of  $i_1 / w$  as a function of  $\alpha$  using N for a square plate.

The normal force N is given by:

$$N = C_n * \frac{1}{2}\rho V^2 * h * w \quad (\text{N}) \quad (29)$$

(23) + (29) gives:

$$M_{vt} = C_n * \frac{1}{2}\rho V^2 * h * w * \cos\theta * (R_v + i_1) \quad (\text{Nm}) \quad (\text{for low wind speeds}) \quad (30)$$

$C_n$  is a function of  $\alpha$  like it is given in figure 6.  $i_1$  is also a function of  $\alpha$  and is given in figure 7. For  $\alpha$  it is meant the angle  $\alpha_1$  from figure 1. For  $\alpha_1$  it is valid that:

$$\alpha_1 = \delta + \phi_2 \quad (^\circ) \quad (31)$$

The drag force D, acting on the vane blade, is determined by the component of the wind speed  $V \sin(\phi_2 + \delta)$  perpendicular to the hinge axis. The drag force is given by:

$$D = C_{dv} * \frac{1}{2}\rho V^2 * \sin^2(\phi_2 + \delta) * h * w \quad (\text{N}) \quad (32)$$

$C_{dv}$  is a function of  $\alpha$  and is given in table 2. It is used  $C_{dv}$  to distinguish it from the coefficient  $C_d$  used for the side force on the rotor. For  $\alpha$  it is meant the angle  $\alpha_2$  from figure 2. For  $\alpha_2$  it is valid that:

$$\alpha_2 = 90^\circ - \theta \quad (^\circ) \quad (33)$$

To be able to read  $C_{dv}$  as a function of  $\alpha$ , the relation in between  $C_{dv}$  and  $\alpha$  as given in table 2, is also given as a graph in figure 8. Because D is used only at high wind speeds,  $\alpha$  will be rather small. Therefore the  $C_{dv}$ - $\alpha$  curve is only given for  $0^\circ < \alpha < 40^\circ$ .

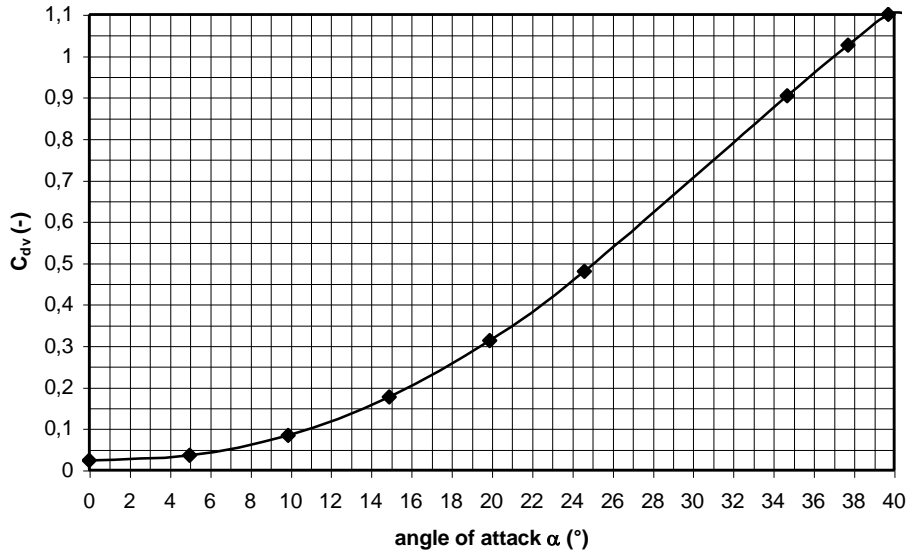

figure 8 Path of  $C_{dv}$  as a function of  $\alpha$  for a square plate for  $\alpha < 40^\circ$

For high wind speeds  $\alpha$  becomes rather small and therefore it is difficult to read  $C_{dv}$  from figure 8. Therefore the  $C_{dv}$ - $\alpha$  curve is also given in figure 9 for  $\alpha < 20^\circ$ .

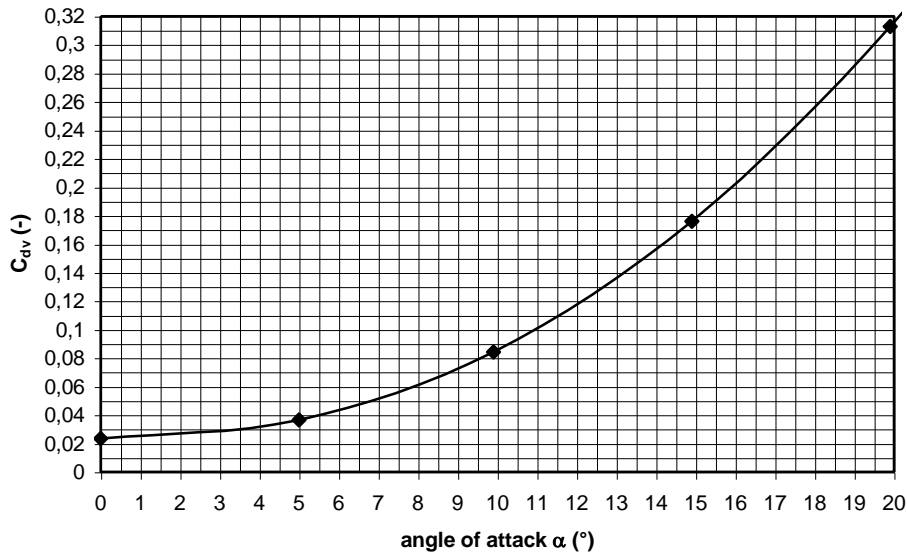

figure 9 Path of  $C_{dv}$  as a function of  $\alpha$  for a square plate for  $\alpha < 20^\circ$

The forces  $F_{va1}$  and  $F_{va2}$  acting on the sections of the vane arm are determined by the component of the wind speed perpendicular to the vane arm. The 2½" vane pipe has a length  $l_1$  and a diameter  $d_1$ . The 1½" vane pipe has a length  $l_2$  and a diameter  $d_2$ .  $F_{va}$  is given by:

$$F_{va} = C_{dva} * \frac{1}{2} \rho V^2 * \sin^2(\phi_1 + \delta) * l * d \quad (N) \quad (34)$$

The drag coefficient  $C_{dva}$  for a cylindrical pipe depends on the Reynolds value and on the pipe roughness but is 1.18 for a smooth pipe for Reynolds smaller than  $10^5$ . The relation is given by a rather complex figure as figure 54 in report R 999 D. Only the line for a smooth pipe is copied as figure 10. In the original graph the x-axis and the y-axis are both logarithmic. However, a logarithmic graph is very difficult to read accurately. Therefore the axis of figure 10 are made linear. The values for  $C_{dva}$  for Reynolds larger than  $2.2 \cdot 10^5$  are not given in figure 54 of R 999 D but are estimated copying the shape of the curves for higher roughness.

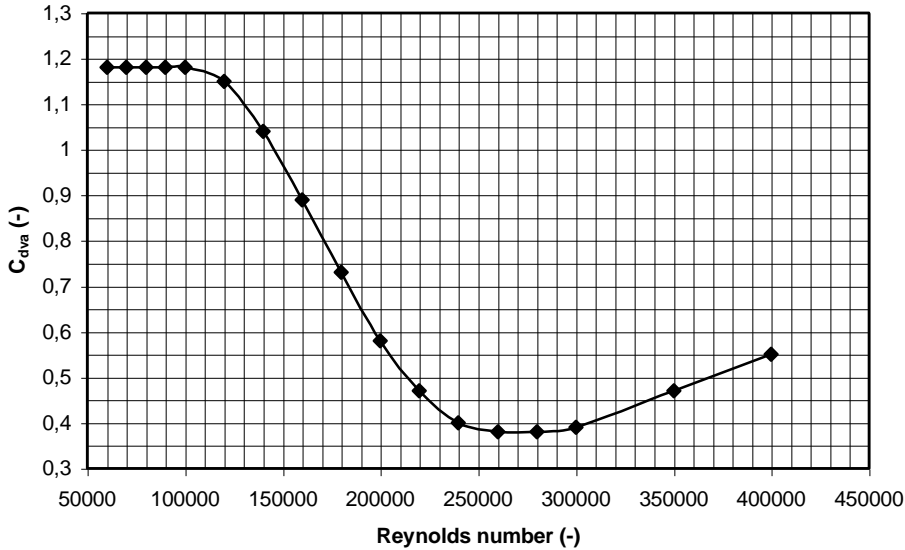

figure 10 Path of  $C_{dva}$  as a function of the Reynolds number for a smooth pipe

The Reynolds value  $Re$  is calculated using formula 71 from R 999 D. This formula is copied as formula 35:

$$Re = V * d / \nu \quad (-) \quad (35)$$

In this formula  $V$  is the wind speed (m),  $d$  is the pipe diameter (m) and  $\nu$  is the kinematic viscosity which is about  $15 \cdot 10^{-6} \text{ m}^2/\text{s}$  for air. I doubt if one has to take the component of  $V$  perpendicular to the pipe for the calculation of the Reynolds number and I suppose one has to take  $V$ . For the 1½" gas pipe with  $d_2 = 0.0483 \text{ m}$ , the Reynolds number is lower than  $10^5$  for wind speeds lower than 31.1 m/s, so then one can use the constant value  $C_{dva} = 1.18$ . For the 2½" gas pipe with  $d_1 = 0.0761 \text{ m}$ , the Reynolds number is lower than  $10^5$  for wind speeds lower than 19.7 m/s, so then one can also use the constant value  $C_{dva} = 1.18$ .

(24) + (32) + (34) gives:

$$\begin{aligned} M_{vt} = & C_{dv} * \frac{1}{2} \rho V^2 * \sin^2(\phi_2 + \delta) * h * w * (R_v + i_2) + \\ & C_{dva1} * \frac{1}{2} \rho V^2 * \sin^2(\phi_1 + \delta) * l_1 * d_1 * \frac{1}{2} l_1 + \\ & C_{dva2} * \frac{1}{2} \rho V^2 * \sin^2(\phi_1 + \delta) * l_2 * d_2 * (l_1 + \frac{1}{2} l_2) \quad \text{or} \end{aligned}$$

$$\begin{aligned} M_{vt} = & \frac{1}{2} \rho V^2 \{ C_{dv} * \sin^2(\phi_2 + \delta) * h * w * (R_v + i_2) + \frac{1}{2} C_{dva1} * \sin^2(\phi_1 + \delta) * d_1 * l_1^2 + \\ & C_{dva2} * \sin^2(\phi_1 + \delta) * l_2 * d_2 * (l_1 + \frac{1}{2} l_2) \} \quad (\text{Nm}) \\ & \text{(for high wind speeds)} \end{aligned} \quad (36)$$

$C_{dv}$  depends on  $\alpha_2$  and is given in figure 8 en 9.



### 3.3 Determination of $M_{vh}$

The vane moment around the hinge axis  $M_{vh}$ , is for low wind speeds determined by  $N$ .  $N$  exerts at a distance  $\frac{1}{2} h$  with respect to the hinge axis (see figure 1). For  $M_{vh}$  it is valid that:

$$M_{vh} = N * \frac{1}{2} h \quad (\text{Nm}) \quad (37)$$

(29) + (37) gives:

$$M_{vh} = C_n * \frac{1}{2} \rho V^2 * w * \frac{1}{2} h^2 \quad (\text{Nm}) \quad (\text{for low wind speeds}) \quad (38)$$

For high wind speeds  $N$  is not used for calculations. Because the lift force  $L$  and the drag force  $D$  are both exerting at the hinge axis, they don't contribute to the moment around this axis. This moment is therefore only determined by the aerodynamic moment  $M$ . For calculation of this moment one has to use the component of the wind speed  $V \sin(\phi_2 + \delta)$  perpendicular to the hinge axis. For  $M_{vh}$  it is valid that:

$$M_{vh} = C_m * \frac{1}{2} \rho V^2 * \sin^2(\phi_2 + \delta) * w * h^2 \quad (\text{Nm}) \quad (\text{for high wind speeds}) \quad (39)$$

The path of  $C_m$  as a function of  $\alpha$  is given in table 2. To be able to read  $C_m$  for small angles  $\alpha$ ,  $C_m$  is given as a function of  $\alpha$  in figure 11 for  $0^\circ < \alpha < 40^\circ$ .

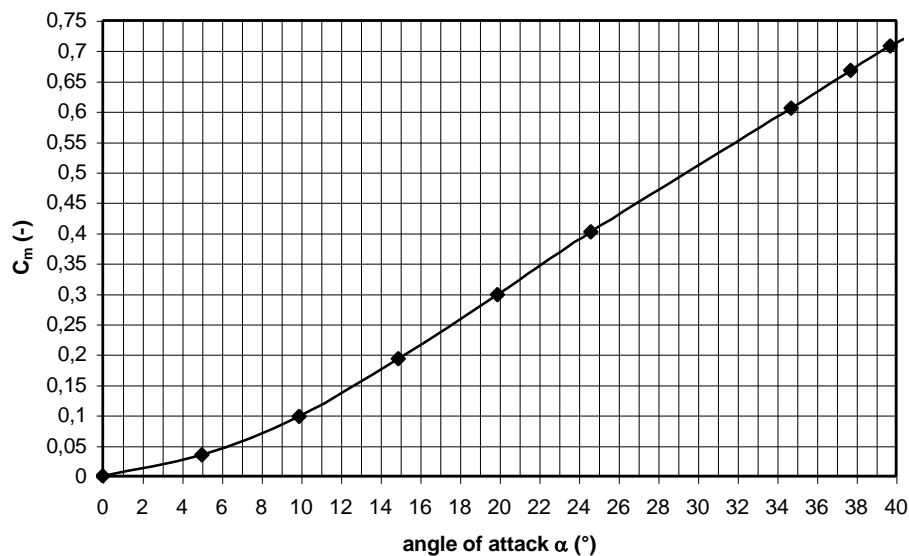

figure 11 Path of  $C_m$  as a function of  $\alpha$  for a square plate for  $\alpha < 40^\circ$

For high wind speeds  $\alpha$  becomes rather small and it is difficult to read  $C_m$  accurately in figure 11. Therefore the  $C_m$ - $\alpha$  curve is also given in figure 12 for  $\alpha < 20^\circ$ .

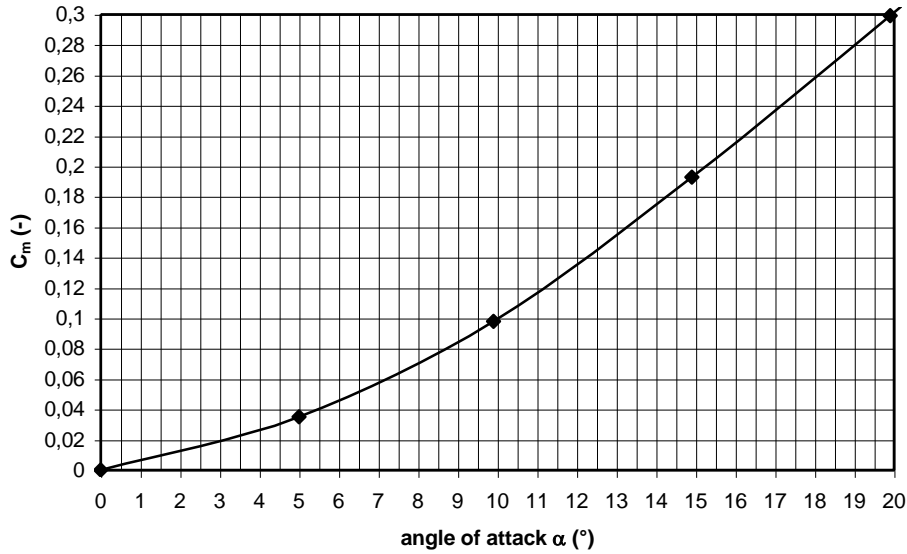

figure 12 Path of  $C_m$  as a function of  $\alpha$  for a square plate for  $\alpha < 20^\circ$

### 3.4 Determination of $M_G$

The weight of the vane blade  $G$ , exerts in the point of gravity at a distance  $\frac{1}{2} h$  from the hinge axis (see figure 1). The weight moment  $M_G$  is given by:

$$M_G = G * \frac{1}{2} h * \sin\theta \quad (\text{Nm}) \quad (40)$$

The vane blade has a thickness  $t$  (m) and a density  $\rho_v$  ( $\text{kg/m}^3$ ). The acceleration of gravity is  $g$  ( $\text{m/s}^2$ ). The weight  $G$  is given by:

$$G = g * \rho_v * w * h * t \quad (\text{N}) \quad (41)$$

(40) + (41) gives:

$$M_G = \frac{1}{2} * g * \rho_v * w * h^2 * t * \sin\theta \quad (\text{Nm}) \quad (\text{for low wind speeds}) \quad (42)$$

For high wind speeds calculations are not made using  $\theta$  but using  $\alpha_2$ . Because  $\theta + \alpha_2 = 90^\circ$  it is valid that  $\sin\theta = \cos\alpha_2$ . This gives:

$$M_G = \frac{1}{2} * g * \rho_v * w * h^2 * t * \cos\alpha_2 \quad (\text{Nm}) \quad (\text{for high wind speeds}) \quad (43)$$

### 3.5 Determination of the moment equations

If there is balance of moments around the tower axis it is valid that:

$$M_{\text{rotor}} = M_{\text{vt}} \quad (44)$$

If there is balance of moments around the hinge axis it is valid that:

$$M_{\text{vh}} = M_G \quad (45)$$

For low wind speeds the yaw angle will be small and therefore for low wind speeds one has to use the formula for  $M_{rotor}$  which is valid for  $0^\circ < \delta < 40^\circ$ . It is allowed to neglect  $F_{va1}$  and  $F_{va2}$ .

### For low wind speeds

(14) + (30) + (44) gives around the tower axis:

$$\pi R^2 (C_t * e * \cos^2 \delta + C_d * f * i * \sin \delta - 0.045 * R \sin 3\delta) = C_n * h * w * \cos \theta * (R_v + i_1) \quad (46)$$

(38) + (42) + (45) gives around the hinge axis:

$$C_n * \frac{1}{2} \rho V^2 = g * \rho_v * t * \sin \theta \quad (47)$$

Formula 47 can be written as:

$$\theta = \arcsin(C_n * \frac{1}{2} \rho V^2 / g * \rho_v * t) \quad (^\circ) \quad (48)$$

### For very low wind speeds

If the rotor is perpendicular to the wind  $\delta = 0^\circ$ . At very low wind speeds the position of the vane blade is almost vertical and therefore  $\cos \theta$  becomes 1 and  $\sin \theta$  becomes 0. Then formula 46 for the balance of moments around the tower axis changes into:

$$\pi R^2 * C_t * e = C_n * h * w * (R_v + i_1) \quad (\text{for very low wind speeds}) \quad (49)$$

Formula 47 for the balance of moments around the hinge axis is no longer relevant because  $\sin \theta = 0$  as the vane blade position is vertical.

Formula 49 can be written as:

$$C_n = \pi R^2 * C_t * e / \{h * w * (R_v + i_1)\} \quad (-) \quad (50)$$

### For high wind speeds

(14) + (36) + (44) gives around the tower axis:

$$\begin{aligned} \pi R^2 (C_t * e * \cos^2 \delta + C_d * f * i * \sin \delta - 0.045 * R \sin 3\delta) = \\ C_{dv} * \sin^2(\phi_2 + \delta) * h * w * (R_v + i_2) + \frac{1}{2} C_{dva1} * \sin^2(\phi_1 + \delta) * d_1 * l_1^2 + \\ C_{dva2} * \sin^2(\phi_1 + \delta) * l_2 * d_2 * (l_1 + \frac{1}{2} l_2) \end{aligned} \quad (\text{for } 0^\circ < \delta < 40^\circ) \quad (51)$$

(15) + (36) + (44) gives around the tower axis:

$$\begin{aligned} \pi R^2 (C_t * e * \cos^2 \delta + C_d * f * i * \sin \delta - 0.0664 * R \cos^2 \delta) = \\ C_{dv} * \sin^2(\phi_2 + \delta) * h * w * (R_v + i_2) + \frac{1}{2} C_{dva1} * \sin^2(\phi_1 + \delta) * d_1 * l_1^2 + \\ C_{dva2} * \sin^2(\phi_1 + \delta) * l_2 * d_2 * (l_1 + \frac{1}{2} l_2) \end{aligned} \quad (\text{for } 40^\circ < \delta < 90^\circ) \quad (52)$$

(39) + (43) + (45) gives around the hinge axis:

$$C_m * \rho V^2 * \sin^2(\phi_2 + \delta) = g * \rho_v * t * \cos \alpha_2 \quad (53)$$

Formula 53 can be written as:

$$\alpha_2 = \arccos\{C_m * \rho V^2 * \sin^2(\phi_2 + \delta) / (g * \rho_v * t)\} \quad (^\circ) \quad (54)$$

In this formula  $C_m$  is a function of  $\alpha_2$  and therefore the correct value of  $\alpha_2$  has to be found by iteration. First a certain value for  $\alpha_2$  is estimated and for this value  $C_m$  is read using figure 11 or 12. Next  $\alpha_2$  is calculated and it is checked if the estimated value of  $\alpha_2$  for which  $C_m$  was read, was correct. If not, a higher or lower value of  $\alpha_2$  is taken till the calculated value is the same as the estimated value.

## 4 Checking of the $\delta$ -V curve of the VIRYA-3.3D

### Checking for very low wind speeds

The estimated  $\delta$ -V curve is given in figure 5. First it is checked if the rotor is perpendicular to the wind for very low wind speeds.

For the VIRYA-3.3D rotor and head geometry it is valid that:  $R = 1.65$  m, assume  $C_t = 0.75$ ,  $e = 0.33$  m,  $h = 0.8$  m,  $w = 0.8$  m,  $R_v = 2.175$  m. If the rotor is perpendicular to the wind using formula 31 it can be calculated that  $\alpha_1 = \phi_2 = 30^\circ$ . In figure 7 it can be read that  $i_1 / w = 0.37$  for  $\alpha = 30^\circ$ . This gives for  $w = 0.8$  m that  $i_1 = 0.295$  m. Substitution of these values in formula 50 gives  $C_n = 1.34$ . In figure 6 it can be read that  $\alpha$  is about  $29^\circ$  for this  $C_n$  value. This differs only  $1^\circ$  from the angle  $\alpha = 30^\circ$  which exists if the rotor is perpendicular to the wind. It means that in reality the rotor will have an angle  $\delta = -1^\circ$  which is OK. So the head geometry is correct for very low wind speeds.

### Checking for $V = 5$ m/s

Next it is checked if the rotor is perpendicular to the wind for a wind speed of 5 m/s. For this wind speed it is no longer allowed to assume that the position of the van blade is vertical. If the rotor is still perpendicular to the wind formula 46 changes into:

$$\pi R^2 * C_t * e = C_n * h * w * \cos\theta * (R_v + i_1) \quad (\text{for low wind speeds}) \quad (55)$$

Formula 55 can be written as:

$$C_n = \pi R^2 * C_t * e / \{h * w * \cos\theta * (R_v + i_1)\} \quad (-) \quad (56)$$

In figure 6 it can be read that  $C_n = 1.37$  for  $\alpha = 30^\circ$ , assume  $\rho = 1.2$  kg/m<sup>3</sup>,  $V = 5$  m/s,  $g = 9.81$  m/s<sup>2</sup>. The vane blade is made of meranti plywood with  $\rho_v = 0.6 * 10^3$  kg/m<sup>3</sup>,  $t = 9$  mm = 0.009 m. Substitution of these values in formula 48 gives that  $\theta = 22.8^\circ$ . This is already a rather large angle. Substitution of  $R = 1.65$  m,  $C_t = 0.75$ ,  $e = 0.33$  m,  $h = 0.8$  m,  $w = 0.8$  m,  $\theta = 22.8^\circ$ ,  $R_v = 2.175$  m en  $i_1 = 0.295$  m in formula 56 gives that  $C_n = 1.45$ . In figure 6 it can be read that  $\alpha = \alpha_1 = 32^\circ$ . Using formula 31 and  $\phi_2 = 30^\circ$  it can be determined that  $\delta = 2^\circ$ . However, this means that formulas 55 and 56 are no longer correct because it was assumed that  $\delta = 0^\circ$ . In figure 4 it can be seen that  $M_{\text{rotor}}$  for  $\delta = 2^\circ$ , is already somewhat lower than for  $\delta = 0^\circ$ . Therefore the rotor will turn out of the wind less than  $2^\circ$ .

The exact value of  $\delta$  is difficult to determine because the moment equations can not be written such that  $\delta$  is explicit. Therefore the method of iteration is used. This means that a certain value of  $\delta$  is estimated and that  $M_{\text{rotor}}$  and  $M_{\text{vt}}$  are calculated for this value of  $\delta$ . For a correct estimation both moments will have about the same value. In the formula of  $M_{\text{vt}}$ , we find the angle  $\theta$  (or  $\alpha_2$ ) and therefore this angle has first to be calculated from the balance of moments around the hinge axis.

Assume  $\delta = 1^\circ$  for  $V = 5$  m/s. Formula 31 en  $\phi_2 = 30^\circ$  en  $\delta = 1^\circ$  gives that  $\alpha_1 = 31^\circ$ . In figure 6 it can be read that  $C_n = 1.41$  for  $\alpha = 31^\circ$ , assume  $\rho = 1.2$  kg/m<sup>3</sup>,  $V = 5$  m/s,  $g = 9.81$  m/s<sup>2</sup>. The vane blade is made of meranti plywood with  $\rho_v = 0.6 * 10^3$  kg/m<sup>3</sup>,  $t = 9$  mm = 0.009 m. Substitution of these values in formula 48 gives that  $\theta = 23.5^\circ$ .

Because  $\delta$  is smaller than  $40^\circ$  formula 14 is used for the determination of  $M_{\text{rotor}}$ . Substitution of  $\rho = 1.2$  kg/m<sup>3</sup>,  $V = 5$  m/s,  $R = 1.65$  m,  $C_t = 0.75$ ,  $e = 0.33$  m,  $\delta = 1^\circ$ ,  $C_d = 1$ ,  $f = 0.42$  m en  $i = 0.014$  in formula 14 gives  $M_{\text{rotor}} = 31.3$  Nm.

Because  $V = 5$  m/s is a low wind speed, formula 30 is used for the determination of  $M_{vt}$ .

Using figure 7 for  $\alpha = 31^\circ$  gives  $i_1 / w = 0.375$ . For  $w = 0.8$  m this gives that  $i_1 = 0.3$  m.

Substitution of  $C_n = 1.41$ ,  $\rho = 1.2$  kg/m<sup>3</sup>,  $V = 5$  m/s,  $h = 0.8$  m,  $w = 0.8$  m,  $\theta = 23.5^\circ$ ,  $R_v = 2.175$  m en  $i_1 = 0.3$  m in formula 30 gives that  $M_{vt} = 30.7$  Nm.

The values found for  $M_{rotor}$  and  $M_{vt}$  are almost the same which means that the assumption that  $\delta = 1^\circ$  for  $V = 5$  m/s is right. This angle  $\delta = 1^\circ$  for  $V = 5$  m/s deviates only very little from the estimated  $\delta$ - $V$  curve of figure 5 and the influence of this angle on the power can be neglected.

### Checking for $V = 6$ m/s

Assume  $\delta = 5^\circ$  for  $V = 6$  m/s. Formula 31 en  $\phi_2 = 30^\circ$  en  $\delta = 5^\circ$  gives that  $\alpha_1 = 35^\circ$ . In figure 6 it can be read that  $C_n = 1.60$  for  $\alpha = 35^\circ$ , assume  $\rho = 1.2$  kg/m<sup>3</sup>,  $V = 6$  m/s,  $g = 9.81$  m/s<sup>2</sup>. The vane blade is made of meranti plywood with  $\rho_v = 0.6 * 10^3$  kg/m<sup>3</sup>,  $t = 9$  mm = 0.009 m. Substitution of these values in formula 48 gives that  $\theta = 40.7^\circ$ .

Because  $\delta$  is smaller than  $40^\circ$  formula 14 is used for the determination of  $M_{rotor}$ . Substitution of  $\rho = 1.2$  kg/m<sup>3</sup>,  $V = 6$  m/s,  $R = 1.65$  m,  $C_t = 0.75$ ,  $e = 0.33$  m,  $\delta = 5^\circ$ ,  $C_d = 1$ ,  $f = 0.42$  m en  $i = 0.014$  in formula 14 gives  $M_{rotor} = 41.9$  Nm.

Because  $V = 6$  m/s is a low wind speed, formula 30 is used for the determination of  $M_{vt}$ . Using figure 7 for  $\alpha = 35^\circ$  gives  $i_1 / w = 0.38$ . For  $w = 0.8$  m this gives that  $i_1 = 0.304$  m.

Substitution of  $C_n = 1.60$ ,  $\rho = 1.2$  kg/m<sup>3</sup>,  $V = 6$  m/s,  $h = 0.8$  m,  $w = 0.8$  m,  $\theta = 40.7^\circ$ ,  $R_v = 2.175$  m en  $i_1 = 0.304$  m in formula 30 gives that  $M_{vt} = 41.6$  Nm.

The values found for  $M_{rotor}$  and  $M_{vt}$  are almost the same which means that the assumption that  $\delta = 5^\circ$  for  $V = 6$  m/s is right. This angle  $\delta = 5^\circ$  for  $V = 6$  m/s deviates somewhat from the estimated  $\delta$ - $V$  curve of figure 5. Because the power is proportional with  $\cos^3\delta$  this results in a decrease of the power with a factor 0.989 which is acceptable.

The angle  $\theta = 40.7^\circ$  found for  $V = 6$  m/s is already rather large and therefore this method of calculation can not be used for larger wind speeds. For the wind speed interval in between 6 and 11 m/s the formulas for low and high wind speeds can both not be used because the wind blows about diagonal along the vane blade. It is assumed that it is allowed to use the formulas for high wind speeds for wind speeds larger than 11 m/s. Also for wind speeds higher than 11 m/s,  $\delta$  is found by iteration.

### Checking for $V = 11$ m/s

Assume that the estimated  $\delta$ - $V$  curve of figure 5 is correct. This gives  $\delta = 35^\circ$ . Because  $\delta$  is smaller than  $40^\circ$  we have to use formula 14 for the calculation of  $M_{rotor}$ . For  $M_{vt}$  we have to use formula 36. For  $\alpha_2$  we have to use formula 54. These three formulas are now first made specific for the VIRYA-3.3D to simplify the calculation.

Substitution of  $\rho = 1.2$  kg/m<sup>3</sup>,  $R = 1.65$  m,  $C_t = 0.75$ ,  $e = 0.33$  m,  $C_d = 1$ ,  $f = 0.42$  m en  $i = 0.014$  in formula 14 gives:

$$M_{rotor} = 5.1318 V^2 (0.2475 \cos^2\delta + 0.0059 \sin\delta - 0.0743 \sin 3\delta) \quad (\text{Nm})$$

(for  $0^\circ < \delta < 40^\circ$ )      (57)

Substitution of  $\rho = 1.2 \text{ kg/m}^3$ ,  $h = 0.8 \text{ m}$ ,  $w = 0.8 \text{ m}$ ,  $R_v = 2.175 \text{ m}$ ,  $i_2 = \frac{1}{2} w = 0.4 \text{ m}$ ,  $d_1 = 0.0761 \text{ m}$ ,  $l_1 = 1.2 \text{ m}$ ,  $d_2 = 0.0483 \text{ m}$  en  $l_2 = 1 \text{ m}$  in formula 36 gives:

$$M_{vt} = 0.6 V^2 \{1.648 C_{dv} * \sin^2(\phi_2 + \delta) + 0.0548 * C_{dva1} \sin^2(\phi_1 + \delta) + 0.0821 * C_{dva2} * \sin^2(\phi_1 + \delta)\} \text{ or}$$

$$M_{vt} = 0.6 V^2 \{1.648 C_{dv} * \sin^2(\phi_2 + \delta) + (0.0548 * C_{dva1} + 0.0821 * C_{dva2}) * \sin^2(\phi_1 + \delta)\} \quad (\text{Nm}) \quad (\text{for high wind speeds}) \quad (58)$$

Substitution of  $\rho = 1.2 \text{ kg/m}^3$ ,  $g = 9.81 \text{ m/s}^2$ ,  $\rho_v = 0.6 * 10^3 \text{ kg/m}^3$  and  $t = 0.009 \text{ m}$  in formula 54 gives:

$$\alpha_2 = \arccos\{0.0227 C_m * V^2 * \sin^2(\phi_2 + \delta)\} \quad (^\circ) \quad (59)$$

Assume  $\alpha_2 = 17^\circ$ . In figure 12 it can be read that  $C_m = 0.235$ . Substitution of  $C_m = 0.235$ ,  $V = 11 \text{ m/s}$ ,  $\phi_2 = 30^\circ$  en  $\delta = 35^\circ$  in formula 59 gives that  $\alpha_2 = 58.0^\circ$ . So the assumed value for  $\alpha_2$  is much too low.

Assume  $\alpha_2 = 24.7^\circ$ . In figure 11 it can be read that  $C_m = 0.403$ . Substitution of  $C_m = 0.403$ ,  $V = 11 \text{ m/s}$ ,  $\phi_2 = 30^\circ$  en  $\delta = 35^\circ$  in formula 59 gives that  $\alpha_2 = 24.6^\circ$ . So the assumed angle  $\alpha_2 = 24.7^\circ$  is about right.

Substitution of  $V = 11 \text{ m/s}$  en  $\delta = 35^\circ$  in formula 57 gives  $M_{rotor} = 60.7 \text{ Nm}$ .

For a wind speed of  $V = 11 \text{ m/s}$  the Reynolds values for both vane arm sections are lower than  $10^5$  and therefore  $C_{dva1}$  and  $C_{dva2}$  are both 1.18.

For  $\alpha_2 = 24.7^\circ$  it can be read in figure 8 that  $C_{dv} = 0.48$ . Substitution of  $V = 11 \text{ m/s}$ ,  $C_{dv} = 0.48$ ,  $\phi_2 = 30^\circ$ ,  $\delta = 35^\circ$ ,  $C_{dva1} = 1.18$ ,  $C_{dva2} = 1.18$  and  $\phi_1 = 45^\circ$  in formula 58 gives  $M_{vt} = 58.5 \text{ Nm}$ .

So  $M_{rotor}$  is a little larger than  $M_{vt}$  which means that the rotor will turn out of the wind a little more than  $35^\circ$ . The whole calculation is now repeated for  $\delta = 37^\circ$ .

Assume  $\delta = 37^\circ$ .

Assume  $\alpha_2 = 24.1^\circ$ . In figure 11 it can be read that  $C_m = 0.392$ . Substitution of  $C_m = 0.392$ ,  $V = 11 \text{ m/s}$ ,  $\phi_2 = 30^\circ$  en  $\delta = 37^\circ$  in formula 59 gives that  $\alpha_2 = 24.2^\circ$ . So the assumed angle  $\alpha_2 = 24.1^\circ$  is about right.

Substitution of  $V = 11 \text{ m/s}$  en  $\delta = 37^\circ$  in formula 57 gives  $M_{rotor} = 57.2 \text{ Nm}$ .

For a wind speed of  $V = 11 \text{ m/s}$  the Reynolds values for both vane arm sections are lower than  $10^5$  and therefore  $C_{dva1}$  and  $C_{dva2}$  are both 1.18.

For  $\alpha_2 = 24.1^\circ$  it can be read in figure 8 that  $C_{dv} = 0.46$ . Substitution of  $V = 11 \text{ m/s}$ ,  $C_{dv} = 0.46$ ,  $\phi_2 = 30^\circ$ ,  $\delta = 37^\circ$ ,  $C_{dva1} = 1.18$ ,  $C_{dva2} = 1.18$  and  $\phi_1 = 45^\circ$  in formula 58 gives  $M_{vt} = 58.1 \text{ Nm}$ . Now  $M_{rot}$  has about the same value as  $M_{vt}$  so the assumption that the rotor turns out of the wind by  $37^\circ$  for  $V = 11 \text{ m/s}$  is right. So the rotor will turn out of the wind only  $2^\circ$  more than the estimated value  $\delta = 35$  for  $V = 11 \text{ m/s}$  of figure 5.

### Checking for $V = 15 \text{ m/s}$

Only the calculation which finally results in about the same value for  $M_{rotor}$  and  $M_{vt}$ , will be presented. For  $V = 15 \text{ m/s}$ ,  $\delta$  will be larger than  $40^\circ$ . Therefore formula 15 has to be used to calculate  $M_{rotor}$ . This formula is first made specific for the VIRYA-3.3D.

Substitution of  $\rho = 1.2 \text{ kg/m}^3$ ,  $R = 1.65 \text{ m}$ ,  $C_t = 0.75$ ,  $e = 0.33 \text{ m}$ ,  $C_d = 1$ ,  $f = 0.42 \text{ m}$  and  $i = 0.014$  in formula 15 gives:

$$M_{rotor} = 5.1318 V^2 (0.2475 \cos^2\delta + 0.0059 \sin\delta - 0.1096 \cos^2\delta) \quad \text{or}$$

$$M_{\text{rotor}} = 5.1318 V^2 (0.1379 \cos^2 \delta + 0.0059 \sin \delta) \quad (\text{Nm}) \quad (\text{for } 40^\circ < \delta < 90^\circ) \quad (60)$$

For  $M_{\text{vt}}$  formula 58 is used. For  $\alpha_2$  formula 59 is used.

Assume  $\delta = 54^\circ$ .

Assume  $\alpha_2 = 14.9^\circ$ . In figure 12 it can be read that  $C_m = 0.191$ . Substitution of  $C_m = 0.191$ ,  $V = 15$  m/s,  $\phi_2 = 30^\circ$  en  $\delta = 54^\circ$  in formula 59 gives that  $\alpha_2 = 15.2^\circ$ . So the assumed angle  $\alpha_2 = 14.9^\circ$  is about right. However the whole calculation becomes very sensible for the correct value of  $C_m$ . If  $C_m$  is taken 0.198, the term behind arc cos becomes larger than 1 and no solution is found for  $\alpha_2$ .

Substitution of  $V = 15$  m/s en  $\delta = 54^\circ$  in formula 60 gives  $M_{\text{rotor}} = 60.5$  Nm.

For a wind speed of  $V = 15$  m/s the Reynolds values for both vane arm sections are lower than  $10^5$  and therefore  $C_{\text{dva1}}$  and  $C_{\text{dva2}}$  are both 1.18.

For  $\alpha_2 = 14.9^\circ$  it can be read in figure 9 that  $C_{\text{dv}} = 0.175$ . Substitution of  $V = 15$  m/s,  $C_{\text{dv}} = 0.175$ ,  $\phi_2 = 30^\circ$ ,  $\delta = 55^\circ$ ,  $C_{\text{dva1}} = 1.18$ ,  $C_{\text{dva2}} = 1.18$  and  $\phi_1 = 45^\circ$  in formula 58 gives  $M_{\text{vt}} = 59.8$  Nm.

So  $M_{\text{rotor}}$  has about the same value as  $M_{\text{vt}}$  which means that the assumption that  $\delta = 54^\circ$  for  $V = 15$  m/s is right. So the rotor will turn out of the wind only  $0.9^\circ$  more than the estimated value of  $\delta = 53.1^\circ$  of figure 5.

### Checking for $V = 20$ m/s

For  $M_{\text{vt}}$  formula 58 is used. For  $\alpha_2$  formula 59 is used. For  $M_{\text{rotor}}$  formula 60 is used.

Assume  $\delta = 62^\circ$ .

Assume  $\alpha_2 = 10.6^\circ$ . In figure 12 it can be read that  $C_m = 0.108$ . Substitution of  $C_m = 0.108$ ,  $V = 20$  m/s,  $\phi_2 = 30^\circ$  en  $\delta = 62^\circ$  in formula 59 gives that  $\alpha_2 = 11.6^\circ$ . So the assumed angle  $\alpha_2 = 10.6^\circ$  is about right. However the whole calculation becomes very sensible for the correct value of  $C_m$ . If  $C_m$  is taken 0.111, the term behind arc cos becomes larger than 1 and no solution is found for  $\alpha_2$ .

Substitution of  $V = 20$  m/s en  $\delta = 62^\circ$  in formula 60 gives  $M_{\text{rotor}} = 73.1$  Nm.

For a wind speed of  $V = 20$  m/s the Reynolds values for the  $1\frac{1}{2}$ " gas pipe is lower than  $10^5$  and therefore  $C_{\text{dva2}} = 1.18$ . Substitution of  $V = 20$  m/s,  $d_1 = 0.0761$  m and  $\nu = 15 \cdot 10^{-6}$  in formula 35 gives  $Re_1 = 1.015 \cdot 10^5$ . In figure 10 it can be read that  $C_{\text{dva1}} = 1.18$  for this value of Reynolds, so  $C_{\text{dva1}}$  is still 1.18.

For  $\alpha_2 = 10.6^\circ$  it can be read in figure 9 that  $C_{\text{dv}} = 0.095$ . Substitution of  $V = 20$  m/s,  $C_{\text{dv}} = 0.095$ ,  $\phi_2 = 30^\circ$ ,  $\delta = 62^\circ$ ,  $C_{\text{dva1}} = 1.18$ ,  $C_{\text{dva2}} = 1.18$  and  $\phi_1 = 45^\circ$  in formula 58 gives  $M_{\text{vt}} = 72.9$  Nm.

So  $M_{\text{rotor}}$  has about the same value as  $M_{\text{vt}}$  which means that the assumption that  $\delta = 62^\circ$  for  $V = 20$  m/s is right. So the rotor will turn out of the wind only  $1.2^\circ$  less than  $\delta = 63.2^\circ$  which belongs to the estimated  $\delta$ - $V$  curve of figure 5 but this is acceptable.



### Checking $V = 27$ m/s

For  $M_{vt}$  formula 58 is used. For  $\alpha_2$  formula 59 is used. For  $M_{rotor}$  formula 60 is used.

Assume  $\delta = 67^\circ$ .

Assume  $\alpha_2 = 7.5^\circ$ . In figure 12 it can be read that  $C_m = 0.0608$ . Substitution of  $C_m = 0.0608$ ,  $V = 27$  m/s,  $\phi_2 = 30^\circ$  en  $\delta = 67^\circ$  in formula 59 gives that  $\alpha_2 = 7.6^\circ$ . So the assumed angle  $\alpha_2 = 7.5^\circ$  is about right. However the whole calculation becomes very sensible for the correct value of  $C_m$ . If  $C_m$  is taken 0.0615, the term behind arc cos becomes larger than 1 and no solution is found for  $\alpha_2$ .

Substitution of  $V = 27$  m/s en  $\delta = 67^\circ$  in formula 60 gives  $M_{rotor} = 99.1$  Nm.

For a wind speed of  $V = 27$  m/s the Reynolds values of the 1½" pipe is lower than  $10^5$  and therefore  $C_{dva2} = 1.18$ . Substitution of  $V = 27$  m/s,  $d_1 = 0.0761$  m and  $\nu = 15 \cdot 10^{-6}$  in formula 35 gives  $Re_1 = 1.37 \cdot 10^5$ . In figure 10 it can be read that  $C_{dva1} = 1.07$  for this value of Reynolds.

For  $\alpha_2 = 7.5^\circ$  it can be read in figure 9 that  $C_{dv} = 0.056$ . Substitution of  $V = 27$  m/s,  $C_{dv} = 0.056$ ,  $\phi_2 = 30^\circ$ ,  $\delta = 67^\circ$   $C_{dva1} = 1.07$ ,  $C_{dva2} = 1.18$  and  $\phi_1 = 45^\circ$  in formula 58 gives  $M_{vt} = 98.2$  Nm.

So  $M_{rotor}$  has about the same value as  $M_{vt}$  which means that the assumption that  $\delta = 67^\circ$  for  $V = 27$  m/s is right. Using formula 1 and  $V_{rated\ th} = 9.0101$  m/s it can be calculated that  $\delta = 70.5^\circ$  for the estimated ideal  $\delta$ -V curve for  $V = 27$  m/s. So the rotor will turn out of the wind  $3.5^\circ$  less than the value which belongs to the estimated ideal  $\delta$ -V curve but this is acceptable.

### Checking for $V = 35$ m/s

For  $M_{vt}$  formula 58 is used. For  $\alpha_2$  formula 59 is used. For  $M_{rotor}$  formula 60 is used.

Assume  $\delta = 71^\circ$ .

Assume  $\alpha_2 = 5.2^\circ$ . In figure 12 it can be read that  $C_m = 0.0372$ . Substitution of  $C_m = 0.0372$ ,  $V = 35$  m/s,  $\phi_2 = 30^\circ$  en  $\delta = 71^\circ$  in formula 59 gives that  $\alpha_2 = 4.6^\circ$ . So the assumed angle  $\alpha_2 = 5.2^\circ$  is about right. However the whole calculation becomes very sensible for the correct value of  $C_m$ . If  $C_m$  is taken 0.0374, the term behind arc cos becomes larger than 1 and no solution is found for  $\alpha_2$ .

Substitution of  $V = 35$  m/s en  $\delta = 71^\circ$  in formula 60 gives  $M_{rotor} = 127.0$  Nm.

For a wind speed of  $V = 35$  m/s the Reynolds values for both pipe sections are larger than  $10^5$ . Substitution of  $V = 35$  m/s,  $d_1 = 0.0761$  m and  $\nu = 15 \cdot 10^{-6}$  in formula 35 gives  $Re_1 = 1.78 \cdot 10^5$ . In figure 10 it can be read that  $C_{dva1} = 0.74$  for this value of Reynolds.

Substitution of  $V = 35$  m/s,  $d_2 = 0.0483$  m and  $\nu = 15 \cdot 10^{-6}$  in formula 35 gives  $Re_2 = 1.13 \cdot 10^5$ . In figure 10 it can be read that  $C_{dva2} = 1.17$  for this value of Reynolds.

For  $\alpha_2 = 5.2^\circ$  it can be read in figure 9 that  $C_{dv} = 0.039$ . Substitution of  $V = 35$  m/s,  $C_{dv} = 0.039$ ,  $\phi_2 = 30^\circ$ ,  $\delta = 71^\circ$   $C_{dva1} = 0.74$ ,  $C_{dva2} = 1.17$  and  $\phi_1 = 45^\circ$  in formula 58 gives  $M_{vt} = 126.6$  Nm.

So  $M_{rotor}$  has about the same value as  $M_{vt}$  which means that the assumption that  $\delta = 71^\circ$  for  $V = 35$  m/s is right. Using formula 1 and  $V_{rated\ th} = 9.0107$  m/s it can be calculated that  $\delta = 75.1^\circ$  for the estimated ideal  $\delta$ -V curve for  $V = 35$  m/s. So the rotor will turn out of the wind  $4.1^\circ$  less than the value which belongs to the estimated ideal  $\delta$ -V curve but this is acceptable.

The calculated values of  $\delta$  for  $V = 0, 5, 6, 11, 15, 20, 27$  and  $35$  m/s are now given in figure 13 together with the extended ideal curve of figure 5.

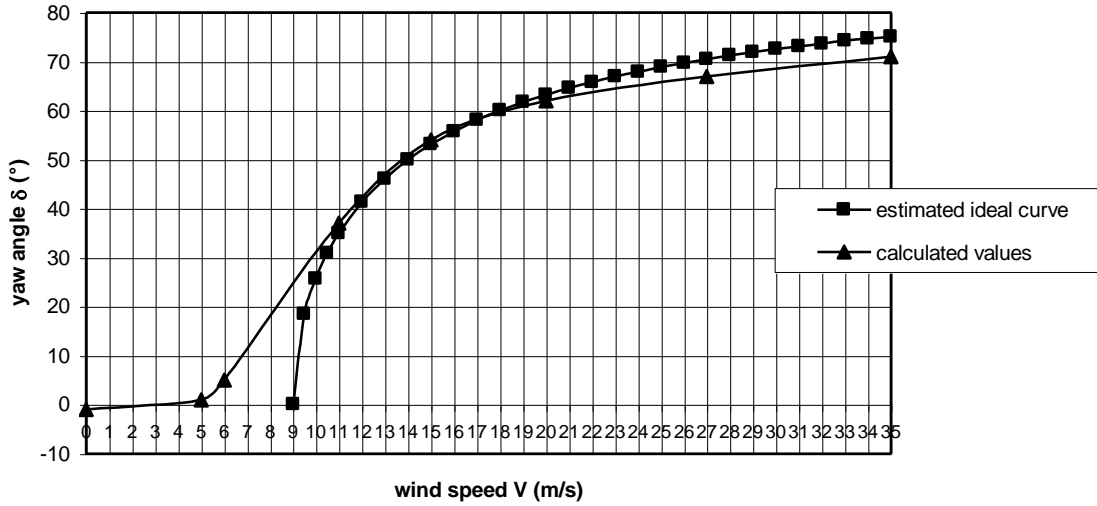

figure 13 The estimated ideal en the calculated  $\delta$ -V curve of the VIRYA-3.3D windmill

In figure 13 it can be seen that the calculated  $\delta$ -V curve is laying very close to the estimated ideal  $\delta$ -V curve for wind speeds higher than  $V = 11$  m/s. Both curves intersect at a wind speed of about 17 m/s. The calculated  $\delta$ -V is laying a little lower than the estimated ideal  $\delta$ -V curve for wind speeds higher than about 17 m/s. The calculated  $\delta$ -V curve intersects with the x-axis for a wind speed of about 3 m/s.

To be able to see the differences for low wind speeds, figure 13 is also given as figure 14 for  $V < 20$  m/s. For the calculated curve, values for  $V = 7, 8, 9$  and  $10$  m/s are added based on the curve drawn by Excel.

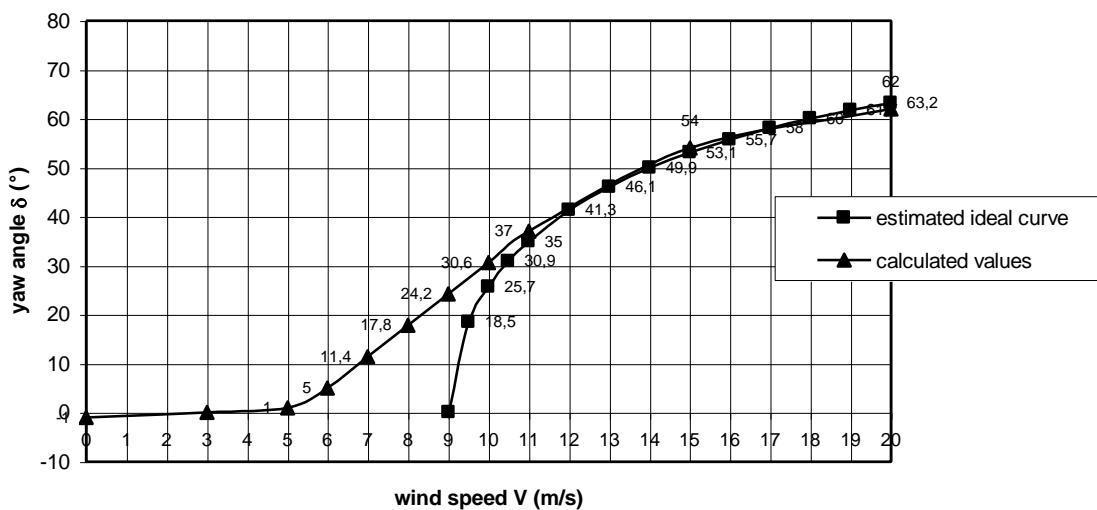

figure 14 The estimated ideal en the calculated  $\delta$ -V curve of the VIRYA-3.3D windmill for  $V < 20$  m/s and with added values for the calculated curve for  $V = 3, 7, 8, 9$  and  $10$  m/s

In between wind speeds of 11 and 35 m/s the estimated ideal curve is rather well approached. However, for wind speeds in between 5 and 11 m/s the rotor turns out of the wind more than according to the ideal  $\delta$ -V curve if the power and the forces have to be limited by the values belonging to the estimated rated wind speed of 11 m/s. But the ideal  $\delta$ -V curve can never be followed exactly for wind speeds just above  $V_{rated\ th}$  because there, a very large increase of  $\delta$  is required for a small increase of  $V$ . Therefore a certain range of  $V$  is necessary for which the rotor turns out of the wind more than according to the ideal  $\delta$ -V curve. Comparing figure 14 with figure 5 shows that the calculated  $\delta$ -V curve is also laying very close to the estimated  $\delta$ -V curve for moderate wind speeds, so it is acceptable to use figure 5 to calculate the load on the rotor and to calculate the P-n curves.

The loss of power due to the yaw angle  $\delta$  is proportional to  $\cos^3\delta$ . For the calculated and for the estimated ideal  $\delta$ -V curve,  $\cos^3\delta$  has been calculated for wind speeds in between 3 and 27 m/s and is given in table 3. The calculated values have indices "cal" and the ideal values have indices "id". The ratio  $\cos^3\delta_{cal} / \cos^3\delta_{id}$  has also been calculated and is given in table 3 and also in figure 15.

V (m/s)	$\delta_{cal}$ (°)	$\cos^3\delta_{cal}$ (-)	$\delta_{id}$ (°)	$\cos^3\delta_{id}$ (-)	$\cos^3\delta_{cal}/\cos^3\delta_{id}$ (-)
3	0	1	0	1	1
5	1	0.9995	0	1	0.9995
6	5	0.9886	0	1	0.9886
7	11.4	0.9420	0	1	0.9420
8	17.8	0.8632	0	1	0.8632
9	24.2	0.7589	0	1	0.7589
9.0107	24.3	0.7571	0	1	0.7571
10	30.6	0.6377	25.7	0.7316	0.8717
11	37	0.5094	35	0.5497	0.9267
15	54	0.2031	53.1	0.2165	0.9381
20	62	0.1035	63.2	0.0917	1.1287
27	67	0.0597	70.5	0.0372	1.6048

table 3 Calculated values  $\cos^3\delta_{cal}$ ,  $\cos^3\delta_{id}$  and  $\cos^3\delta_{cal} / \cos^3\delta_{id}$

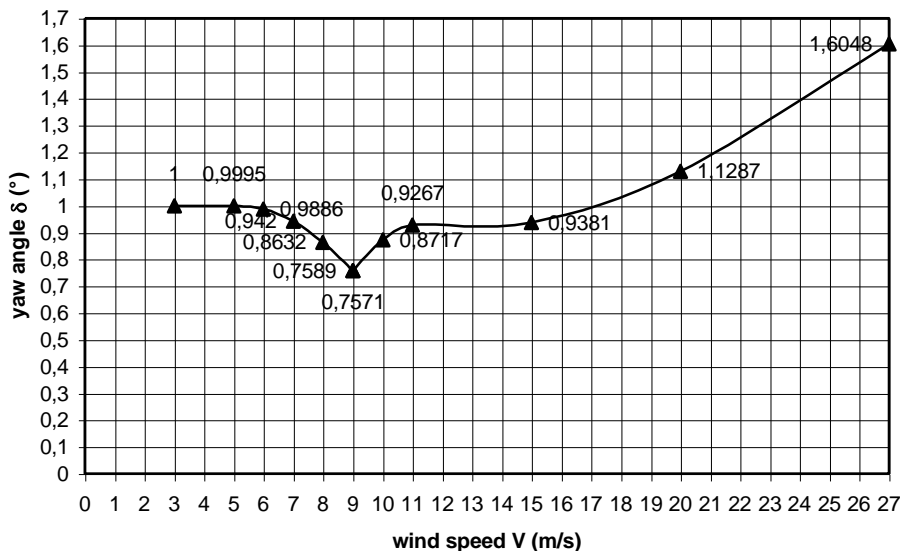

figure 15 Calculated values for  $\cos^3\delta_{cal} / \cos^3\delta_{id}$

In figure 15 it can be seen that the loss of power by not following the ideal  $\delta$ -V curve is only substantial for wind speeds in between 7 and 11 m/s. As wind speeds below 7 m/s are most general available, the calculated  $\delta$ -V curve is certainly acceptable.

## 5 References

- 1 Kragten A. Safety systems for water pumping windmills, report R 999 D, April 1989, (former) Wind Energy Group, Faculty of Fluid Dynamics, Department of Physics, University of Technology Eindhoven, The Netherlands (probably no longer available).
- 2 Kragten A. Method to check the estimated  $\delta$ -V curve of the hinged side vane system and checking of the  $\delta$ -V curve of the VIRY-4.2 windmill, December 2004, free public report KD 213, engineering office Kragten Design, Populierenlaan 51, 5492 SG Sint-Oedenrode, The Netherlands.
- 3 Kragten A. The hinged side vane system as a safety mechanism for windmills, report R 515 D, January 1982, (former) Wind Energy Group, Faculty of Fluid Dynamics, Department of Physics, University of Technology Eindhoven, The Netherlands (probably no longer available).
- 4 Kragten A. Rotor design and marching for horizontal axis wind turbines, free public report KD 35, July 1999, engineering office Kragten Design, Populierenlaan 51, 5492 SG Sint-Oedenrode, The Netherlands.
- 5 Kragten A. Windtunnelmetingen aan het kantelrotormechanisme ter beveiliging van windmolens, in Dutch, report R 344 D, July 1978, (former) Wind Energy Group, Faculty of Fluid Dynamics, Department of Physics, University of Technology Eindhoven, The Netherlands (probably no longer available).
- 6 Hageman A. Catalogue of Aerodynamic Characteristics of Airfoils in the Reynolds number range  $10^4 - 10^6$ , report R 443 D, July 1980, (former) Wind Energy Group, Faculty of Fluid Dynamics, Department of Physics, University of Technology Eindhoven, The Netherlands (probably no longer available but I have a scanned version).